

bilz

Quick change system for industrial robots

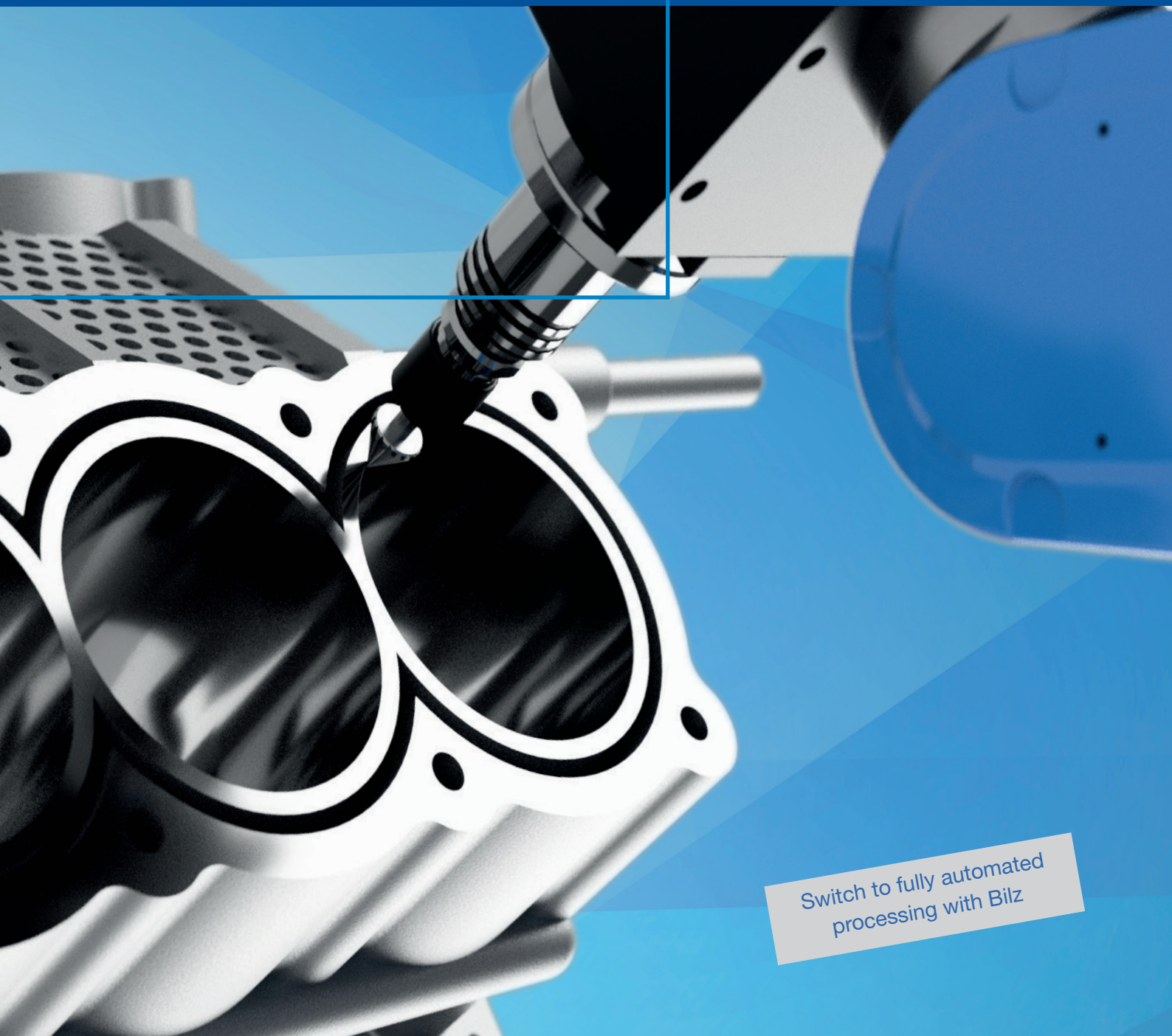

Switch to fully automated
processing with Bilz

Precise, robust, simple to apply – The quick change connection for reliable tool exchange

The AOCS (Automatic Orientation Clamping System) from BILZ enables fully automatic tool changing when machining with robots.



AOCS in combination with ETO engraving chuck

How it works

The very high-quality AOCS system enables a position-independent tool change via a star-shaped coupling mount. The machine spindle, for example, does not have to be positioned into a special fixture for this.

The tool-change is completed with the help of a special change station, this facilitates the pushing back of the coupling sleeve. The spindle can be installed stationary or mounted on the robot.

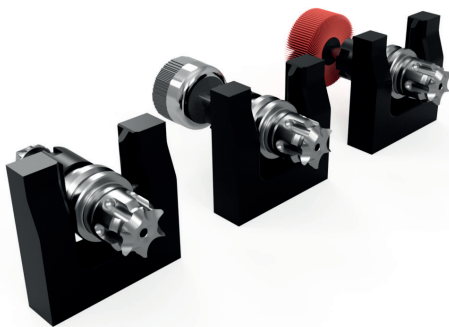
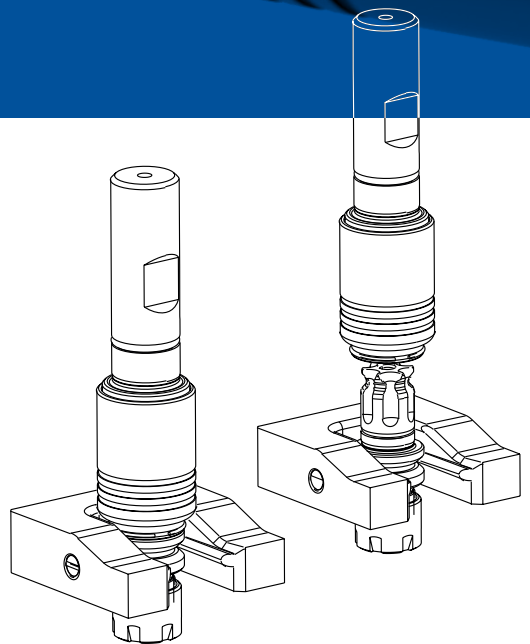

Tool-guided machining:

The use of the AOCS quick-change system makes tool-guided machining more beneficial: the advantages are the significantly smaller moving loads and the reduction of the working space

Workpiece guided machining:

Used when the processing focus is on minimising cycle times. AOCS supports you here with the quick changing of worn tools with simple automation processes.

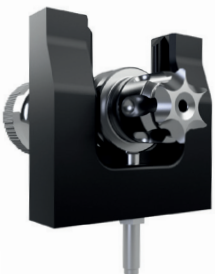

NEW

OUR AOCS TOOL STORAGE SYSTEM CAN BE EQUIPPED WITH SENSOR TECHNOLOGY.



Features

- Fast automated tool change
- For tool and workpiece-guided machining
- Independent of the rotational position of the drive spindle
- Axial length compensation in using a compensating compression range, optionally also available with tension compensation
- Machine-side interface according to customer requirements
- Interchangeable with collet chuck as standard or individually adapted

Benefits

- Simple system integration
- Increased productivity due to reduced tool change times
- One chuck for different application-specific interchangeable tooling
- Use with drive spindles with low complexity



The interchangeable connections are available in three sizes. The chucking tools suited to ER11 to ER25 covers the complete clamping range of cutters and tooling from 1mm to 16mm.

The ability to change tooling successfully is the key factor for process optimisation.

The **AOCS** quick change system as a reliable and robust interface for automated tool changes, reduces machine down-time thus saving valuable machine time. The quick-change system can be used independently of the rotational positioning of the drive spindle and can load and unload the desired tooling for brushing, deburring polishing and even grinding applications.

After reaching the magazine location, only an axial movement is required for tool changing. Movement in the direction of the interchangeable connection is necessary. Axial movement in the opposite direction disengages the connection. The **AOCS** quick change system can be used in many ways, it supports your production with deburring, brushing, polishing, grinding, and much more.

Chuck standards

Designation	Max. load	Weight	Ident No.	Location standard
AOC0-35-N-W16	10Nm	0,149	5163138	
AOC1-40-N-W20	30Nm	0,290	5162467	
AOC2-60-N-W25	90Nm	0,827	5162477	

Quick-change inserts

Designation	Max. load	Weight	Ident No.	Quick-change insert
AOA0-ER11M-25-N	7..14Nm (Ø3...Ø6 @ ER11M)	0,038	5161418	
AOA0-ER16M-40-N	10..25Nm (Ø4...Ø10 @ ER16M)	0,067	5161419	
AOA1-ER16M-34-N	10..25Nm (Ø4...Ø10 @ ER16M)	0,090	5162473	
AOA2-ER25M-42-N	30..60Nm (Ø8...Ø16 @ ER25M)	0,342	5162475	



Filing system

Designation	Weight	Ident No.	Filing system
AOSZ0	0,149	5162292	
AOSZ1	0,290	5169202	
AOSZ2	0,827	5169203	
AOSZ0-S (with inductive sensor)	0,149	5183130	
AOSZ1-S (with inductive sensor)	0,290	5183136	
AOSZ2-S (with inductive sensor)	0,827	5183137	

Our AOCs change system from Bilz offers you a high degree of flexibility in your processing line

With the integrated system, tools can be changed fully automatically and without stopping the machining process. This is a great advantage, especially for applications with relatively short change intervals. If a component has to be machined with different tools to accommodate various materials, e.g. cast aluminium, magnesium or plastic housings, a single spindle is usually sufficient.

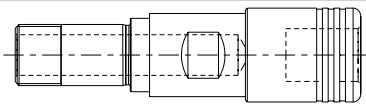
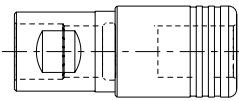
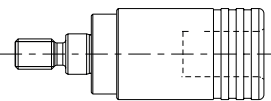
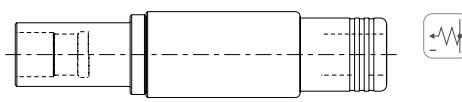
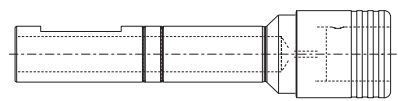
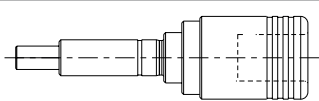
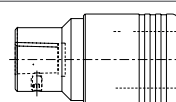
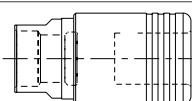
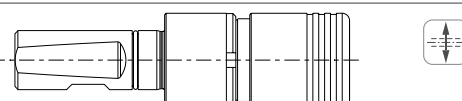
Overview of the Machine-side connections - customer solutions

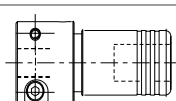
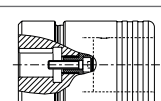
Designation	Weight	Description	Location
AOC0-55-N-S	0,141	Screwed into spindle	
AOC0-55-N-S	0,096	Screwed on to spindle	
AOC00-34-N-S	0,052	Screwed into spindle	
AOC0-116-N-S	0,300	Chuck with 10 mm compression	
AOC2-61-K1-S	1,188	Clamped on Robot spindle	
AOC0-40-N-S	0,104	Chuck with hexagon drive	
AOC2-90-N-B16	0,808	With "B" Taper connection	
AOC0-45-N-S	0,083	Screwed on to spindle	
AOCP1-63-N-W20	0,427	Radial float	
AOC1-80-K3-S	0,603	With external through coolant supply	
AOC0-53-N-S	0,153	Clamping on motor shaft	
AOC2-78-N-S	0,872	Axial spindle clamping for shaft with parallel key	

Special solutions possible on request